

 Class II 220-240V ~ 50/60Hz	Power 12 14 Watts	IP Rating 65	Material UV Powder Coated/Polycarbonate	Warranty 3 Years				
--	-------------------------------	------------------------	---	----------------------------	---	---	---	---

ⓘ CAUTION – Must Be Installed By A Licensed Electrician

Please read instruction manual on **both** sides carefully before installing luminaire.

- Please read instructions for installation of luminaire provided below. Safety of this luminaire and warranty will be voided unless followed.
- Installation and operation of this luminaire must be within accordance with national safety regulations. Unios™ does not warrant any liability when damage is caused by misuse or improper installation.
- This luminaire is void of warranty if any part has been modified. Please visit unios.com/warranty for more information.
- Over-voltage protection units should be installed to prevent electronic control gear from failing due to electrical spikes, e.g. from switching of inductive loads.

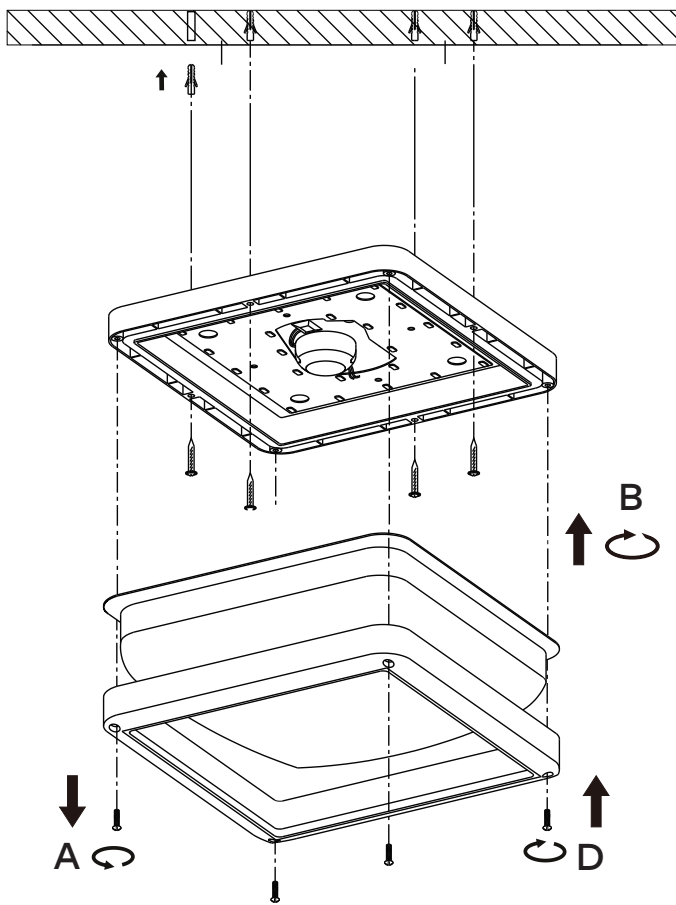

Installation Instructions

- 1 Must be installed by a licensed electrician.
- 2 Before installing, make sure the power supply is switched off.
- 3 Follow the steps in the figure shown for installation:
 - A. Remove cover via mounting screws and detach luminaire body.
 - B. Fix the luminaire body onto the ceiling or wall with screws.
 - C. Terminate mains cable as per instruction (C1, C2 and C3).
 - D. Refix cover to luminaire body.

*Note: The gasket supplied in the luminaire **must** be used during electrical installation to ensure no water ingress through the back of the fitting. It is strongly advised to also use a sealant to ensure a full seal around the cable entry or any other holes.*

Note: After completing above steps, ensure the luminaire is firmly fixed to the mounting plate. The luminaire must be cleaned following these installation instructions. Termination of wiring and installation of the product shall be conducted such that the luminaire's stated IP rating is not affected.

Wiring

This luminaire must be installed in conjunction with electronic control gear (Built-in).

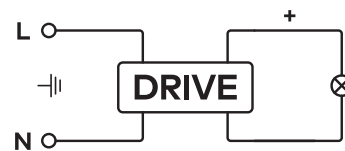
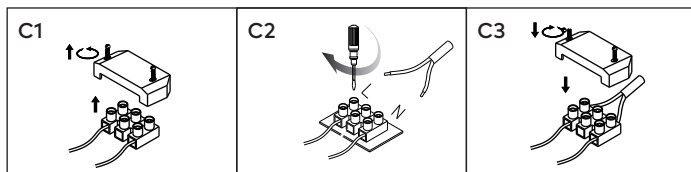

Accessories (Included)



4x Anchor Plugs



4x Phillips Screws



1x Allen Key

Dimming

This luminaire can not be dimmed.
Specific DALI option available.

Cleaning

Before cleaning, disconnect from mains supply and allow luminaire to cool.

Regular cleaning of the luminaire is **strongly recommended**. In harsher conditions, it is recommended that a strict cleaning schedule is in place to ensure no eroding chemicals are left on the surface for long periods. To clean luminaire, only use a damp, microfibre cloth. A dilute solution of a mild pH-neutral liquid detergent can be used for resistant dirt (Solvents must not be used). Please note surface of luminaire must be wiped down with a clean damp microfibre cloth to ensure no residue is left on the surface. Take care not to damage the surface of the luminaire. Do not use high pressure cleaners.

Corrosion Protection

It is important to note that care must be taken during installation or maintenance to ensure that the surface of the luminaire is not damaged. Any damage, which is exposed to moisture will result in corrosion occurring.

Please also note that any chemical applications on the luminaire will cause corrosion of the surface of the luminaire and will void the warranty.



Class II

Luminaire in which protection against electric is provided by double insulation or reinforced insulation.



IP65

Protected against dust completely and Jets of water from all directions.



AC

220-240V 50-60hz AC Supply.



Outdoor Use

This luminaire is suitable for outdoor use, taking in consideration of the IP rating.

